

16-port 10/100M Ethernet, Din-Rail, Layer2, Unmanaged

➤ Features

- Support 16-port 10/100M Base-T(X);
- Plug-and-play, no configuration is required;
- Support relay alarm output;
- Support indicator status display;
- Support IP40 protection, aluminum alloy shell, fanless design;
- Support Broadcast storm suppression;
- Support dual DC12-48V or single AC/DC 220V power supply;
- Power supply input support anti-reverse protection and non-polarity;
- Support over Voltage, over current, EMC protection;
- Support -40-75°C wide operating temperature range;
- DIN-Rail or wall Installation;
- Warranty:5years

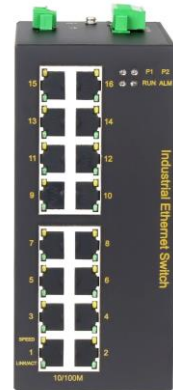

➤ Introduction

UPCOM IES4016 is a rugged industrial grade, Din-Rail, layer2, Unmanaged Ethernet switch which supports 16-port 10/100M Base-T(X). Plug and play, easy to install, no configuration is required, can be operated at wide temperatures range from -40 to 75°C. two independent power circuits ensure the normal operation of the device when one power supply is faulty.

IES4016 adopts standard Industrial design, IP40 protection, aluminum alloy shell, support Din-rail or wall installation, fanless design, support EMC level 4 protection, dual power DC12-48V or single AC/DC220V optional, can meet the requirement of various Industrial automation, Data Center Network, Intelligent Transportation System, Electric Power Industry, and new energy, etc.

➤ Application

- Intelligent Transportation System
- Industrial Automation
- Security Surveillance
- New Energy and Utilities
- Data Center Network
- Electric Power Industry
- Oil&Gas
- Smart City

➤ Specification

Specification	
Product Name	16-port 10/100M Din-Rail Unmanaged layer2 Industrial Ethernet switch
Product Model	IES4016
Port Definition	16-port 10/100M RJ45
Terminal block for power input	5.08mm terminal block
Terminal block for relay alarm	5.08mm terminal block, 1A@24VDC
Protocol Standard	IEEE802.3(Ethernet), IEEE802.3u(100Base-TX&100Base-FX)
	IEEE802.3x(Flow control)
Switch capability	
MAC Table Size	8K
Backplane bandwidth	3.2Gbps
Switch Delay	<5μs
Communication distance	
Twisted-pair	100m(CAT5/CAT5e cable)
Multi-mode fiber	10/100Base multi-mode: 1310nm 2km
Single mode fiber	10/100Base single mode: 1310nm 20km; 1550nm 40/60/80/100/120km
LED indicator lights	
Front panel LED lights	Port light: LINK/ACT;SPEED;
	System work light: RUN
	Power LED: PWR1/PWR2
Power	
Input power	Dual power DC12-48V or Single power AC/DC220V
Full-load consumption	<10W
Overload protection	support
Inversed protection	support
Redundancy protection	support
Working Environment	
Operating Temperature	-40°C~75°C
Storage temperature	-40°C~85°C
Ambient Humidity	5%~95% (non-condensing)
Physical Characteristics	
Shell	IP40 protection, aluminum alloy shell
Installation	35mm din-rail Installation
Dimension	72mm*156mm*120mm

Industry standard	
EMC	EN61000-4-2(ESD), Level 4 EN61000-4-3(RS), Level 4 EN61000-4-4(EFT), Level 4 EN61000-4-5(Surge), Level 4 EN61000-4-6(CS), Level 4 EN61000-4-8, Level 5
Impact	IEC60068-2-27
Falling	IEC60068-2-32
Shock	IEC60068-2-6
Warranty	
Warranty	5 Years
Certification	CE, FCC, RoHS

➤ Dimension

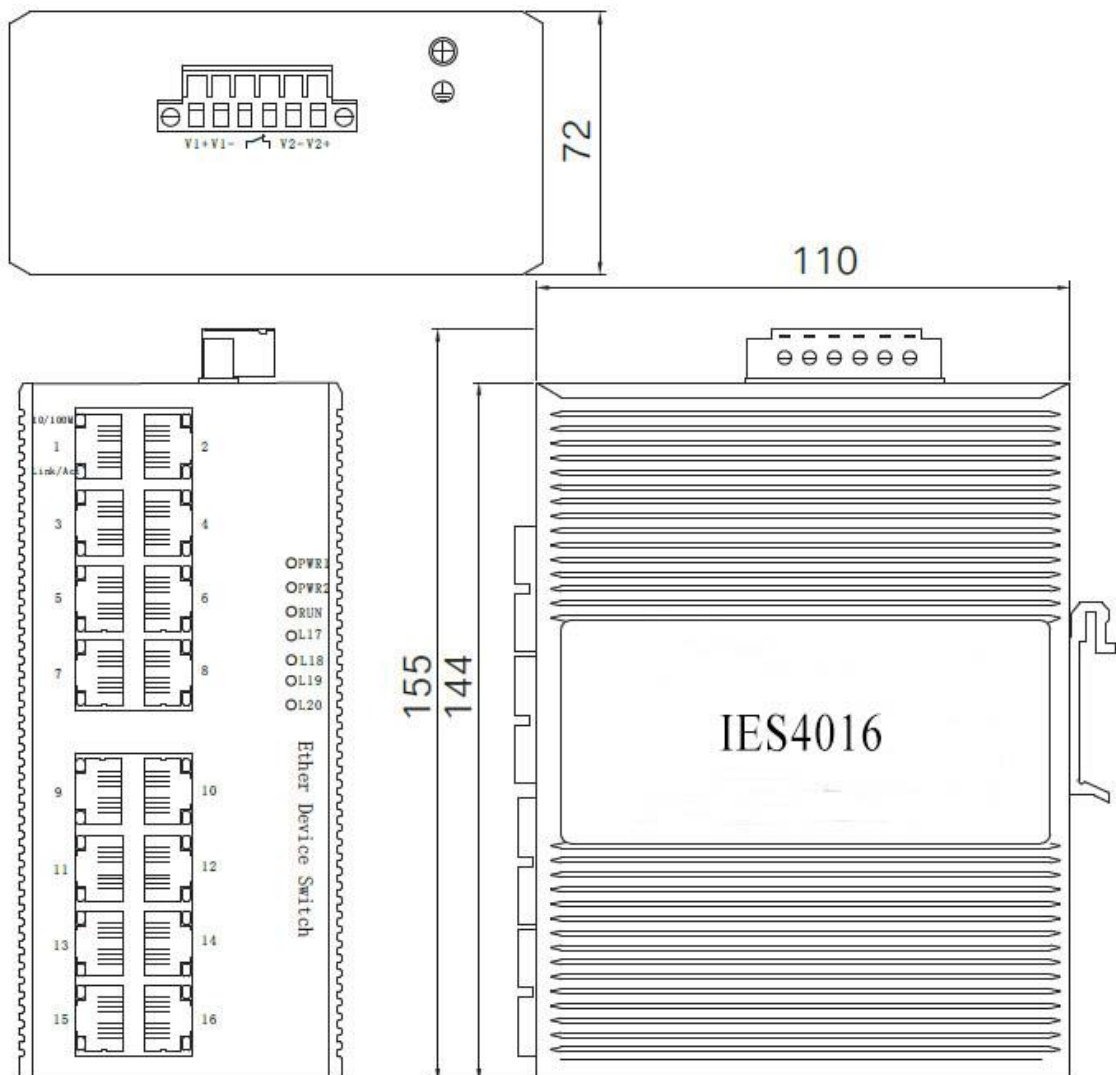

➤ Connection

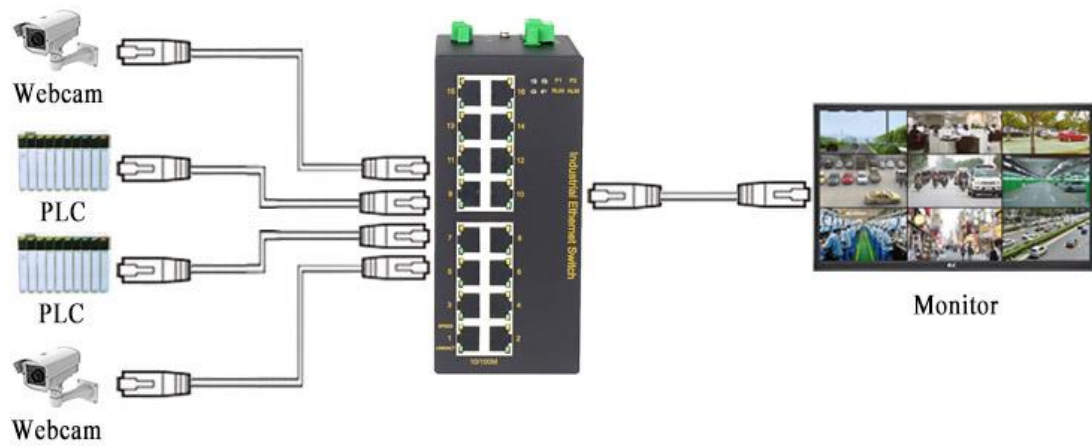

➤ Ordering Information

Model NO.	Description
IES4016	16-port 10/100M Base-T(X), Dual DC12-48V
IES4016-AD220	16-port 10/100M Base-T(X), Single AC/DC220V

➤ Packing List

- Industrial Ethernet Switch *1
- User manual * 1
- Certificate of quality * 1
- Warranty card * 1